

USER'S MANUAL HAKI STAIR TOWER

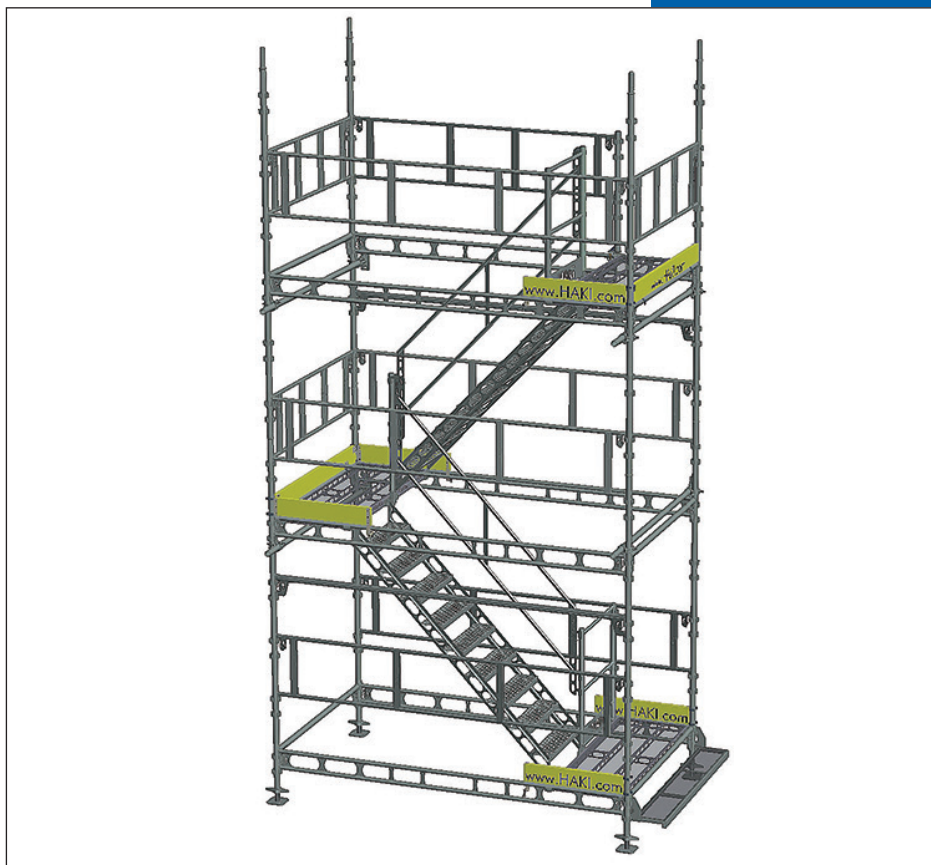

Important information

HAKI's product liability and user's manuals apply only to scaffolds that are entirely composed of components that have been made and supplied by HAKI.

HAKI's type examination certificate applies only to scaffolds consisting of materials, dimensions and design in accordance with those specified in the documentation upon which this certificate is based.

HAKI's scaffold systems must not be erected using components of makes other than HAKI or be connected to scaffolds of makes other than HAKI. In such cases, a special study of load-bearing capacity must be carried out. However, HAKI has no objection to the customary addition of scaffold tubes and approved couplers to the scaffold.

Adding components from different suppliers may invalidate the insurance cover.

This user's manual is based on a minimum of 2 competent erectors wearing work restrain Twin Tool lanyards of fixed length of 800 mm(including Fittings).

This user's manual is to be used in conjunction with HAKI training courses.

A user's manual should be provided to the user together with the scaffolding.















HAKI reserves the right to make technical modifications on a continual basis.

The latest versions of HAKI user's manuals can be downloaded from our website, www.HAKI.com.

For scaffold structures that are not covered by this user's manual, please contact HAKI's technical department.

HAKI colour code

Horizontals and diagonals are marked with their nominal sizes (bay sizes) and a colour code. The marking is a useful means of identification when erecting and handling the scaffold material.

564 	1050 	1964 	3050 
700 	1250 	2050 	3650 
770 	1550 	2500 	4050 
1010 	1655 	2550 	

Forces and dimensions

1000 N = 1 kN ~ 100 kg

10 N ~ 1 kg

All measurements in mm

© Copyright HAKI AB, 2019

The reproduction of text and pictures/illustrations without HAKI's permission is prohibited.

HAKI Stair Tower

Following examination by the SP Technical Research Institute of Sweden, the HAKI Stair Tower system has been issued with a Type Examination Certificate in accordance with the requirements of Ordinance AFS 2013:4 of the Swedish Work Environment Authority Code of Statutes and SS-EN 12810-1 – Certificate No. 14 55 05. The calculations were carried out using method 4026 of the SP Technical Research Institute of Sweden.

General

The HAKI Stair Tower system consists of HAKI Universal standards, beams, diagonal braces and guardrails and the following components that are designed specifically for stair towers: landings, stair flights, handrails, toeboards, etc. Stair towers are erected with bay widths of 1655 mm and bay lengths of 3050 mm and with 2000, 1500 or 1000 mm between lifts.

ERB and LBL beams can be used as both ledger beams and transoms.

The stair tower can be erected both as an independent entity or integrated into a scaffold.

Components for the HAKI Stair Tower system are hot-dip galvanized.

Marking

All components with the exception of locking catches, locking pins, etc. come permanently marked with the HAKI logo and the last two figures of the year of manufacture (■S19).

All load bearing components are marked for full traceability.









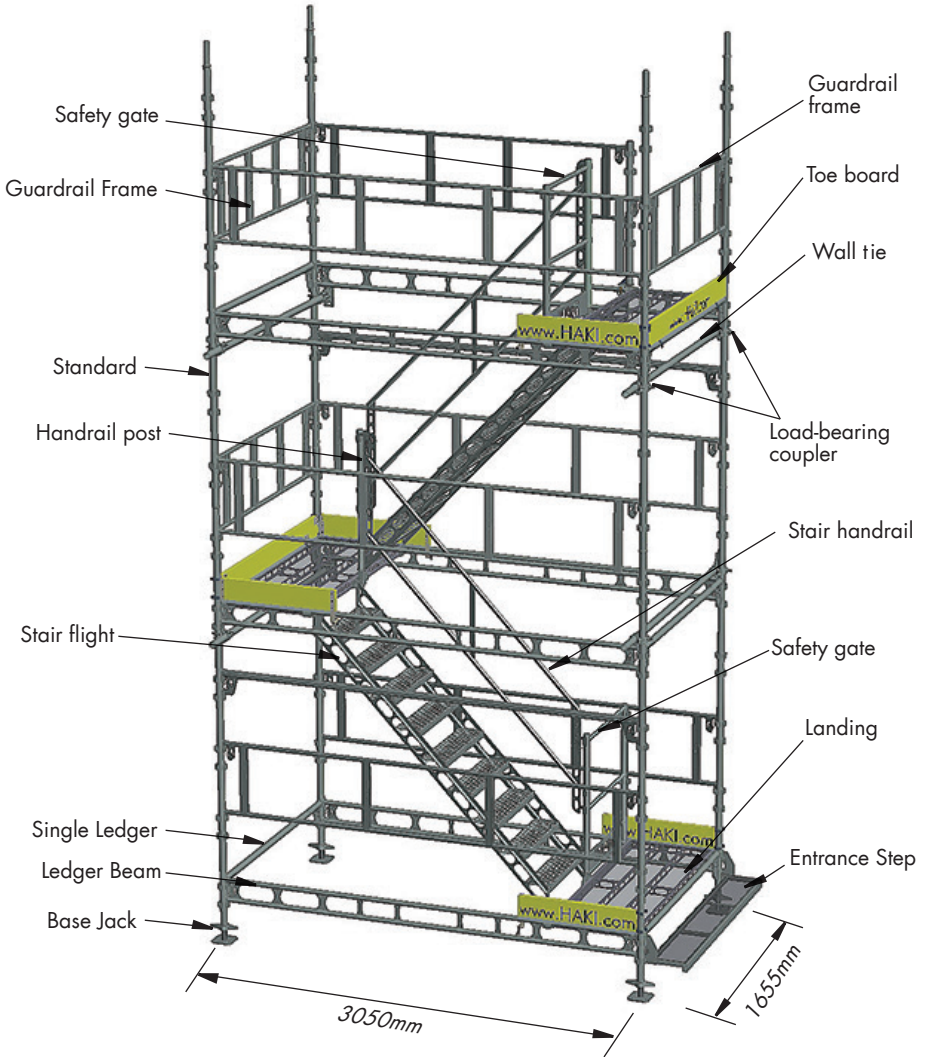

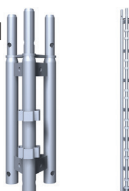
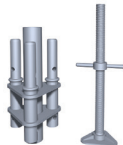
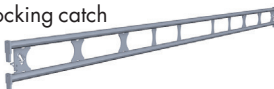
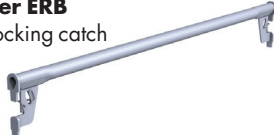

IMPORTANT



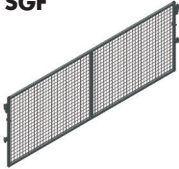

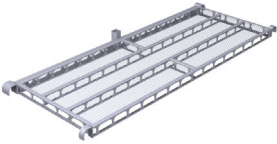

**ENGAGE LOCKING CATCHES AS EACH
COMPONENT IS FIXED**





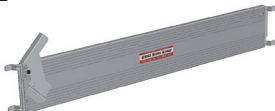

Name	Code/Data	Item No.	Weight(kg)
Base Jack BS Adjustable 55-570 mm 		2071000	5.0
Standard S Standard joint with spigot Pockets at same level Ø48 mm 	500 1000 1500 2000 3000	7016050 7016100 7016150 7016200 7016300	2.9 5.3 7.7 10.1 15.2
Tripod With pockets on one standard Pockets at same level Ø 48 mm 	500 1000 2000 3000	7203340 7203341 7203342 7203343	10.0 17.3 31.8 45.8
Adapter tripod 	Adapter tripod 60 Base jack BS 60	7203312 2071061	11.6 15.6
Ledger beam LBL With spring locking catch Ø 34 mm 	1655 3050	7021162 7021302	6.7 12.3
Single Ledger ERB With spring locking catch Ø 48 mm 	1655 3050	7022161 7022301	6.3 11.3
Guardrail Frame GFL With spring locking catch 	1655 2210 2357 3050	7052164 7052222 7052232 7052304	7.4 8.6 8.9 10.5

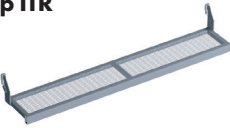



Name	Code/Data	Item No.	Weight(kg)
Safety gate with net SGF Adjustable in height	1655	7055161	17.0
	3050	7055300	26.8
			
Diagonal Brace With wedge couplers Ø48 mm DS 1655 L=2235 DS 3050 L=3400	1655	7122164	10.1
	3050	7121304	14.2
			
STS Landing		7095001	19.2
			
STS Flight	1000	7101101	38.5
	1500	7101151	28.6
	2000	7101201	33.9
			
STS Handrail Post	1000	7015102	4.2
			
STS Handrail Post Wedge	1000	7015104	4.6
			
STS handrail	1000	7058103	7.0
	1500	7058153	7.5
	2000	7058203	8.4
			

Name	Code/Data	Item No.	Weight(kg)
STS Safety gate	SGTS	7053002	10.9
			
Folding Guard Frame	SGS	7053004	5.8
			
STS Top Guard Frame	SGS	7053003	7.6
			
Guardrail post Guardrail post SSKS for erection on ERB single tube beam and SS for erection on LB ledger beam. SSKS jaw width 22 mm	SSKS 22 mm SS 1000	7015006 7015000	6.1 6.1
			
Toeboard AL	770 1655 2210 3050	4161077 4161161 4161221 4161301	1.4 2.9 4.0 5.5
			
STS Toeboard Landing	873 1655	2025085 2025159	3.2 4.5
			
Top Toeboard		7900029	3.2
			
STS Entrance step ITR	1655	7103160	14.7
			

Supplementary components

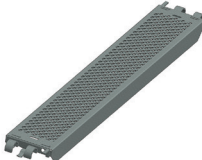
Name	Code/Data	Item No.	Weight(kg)
Locking pin For reinforcing standard joints in connection with tensile load, e.g. when stair tower is suspended or when lifting stair tower. 		5141257	0.3
Spring pin Ø 12 For locking stair flight onto landing, e.g. when lifting stair tower. Applies only to symmetrical stair towers. 		2113100	0.1

Erection accessories

Name	Code/Data	Item No.	Weight(kg)
Steel Plank SPL LK 6 	1655x230x90	2152162	12.5
Light Deck AL LK 3 	1655x600	4071162	13.5
Double Rider 	21	7208033	2.4
Advanced Guardrail Tool 	AL	4052001	1.4

For other accessories, see HAKI Component List.

Information on safety when erecting and dismantling

1. Carry out local risk assessment and method statement.
2. Make sure that all lifting equipment to be used, e.g chain hoists, lifting ropes, pulley blocks, etc., has been thoroughly tested and approved by an authorised person in accordance with local regulations.
3. Check that tools and protective equipment are available at the worksite.
4. Wear appropriate personal safety equipment at all times, e.g safety harnesses, proper independence lifelines with suitable fixings, etc.
5. When erecting and dismantling a scaffold, robust temporary decking must be used as temporary platforms for the scaffolders.
6. Always make sure that the safety locking devices that prevent a platform lifting off have been activated once a platform has been installed.
7. Study all relevant instructions or safety directions from the manufacturers of the various scaffolds that are to be used.
8. Never climb up a scaffold from the outside. Always use the stairs, ladders or climbing frames that are designed to provide access to the upper decks from the inside of the scaffold.
9. If the scaffold is to be used outdoors, erection or dismantling work must be discontinued if the weather conditions are severe. Make sure that all loose components are properly fixed before leaving the scaffold.
10. Scaffolding work must be done by “competent operatives” under the supervision of a “competent person”.
11. Lifting equipment must not be attached to a free-standing scaffold.
12. Beware of any overhead power lines nearby.
13. Always observe and comply with the regulations issued by the local authorities concerned.
14. Erectors/dismantlers should always be clipped to a single ledger or ledger beam during erection/dismantling. Reference should also be made to section “Personal Safety Equipment” in the Universal User manual.

Before erecting the stair tower, check and flatten out the ground. The ground must not be subject to uneven settlement. The ground's bearing capacity may be improved with the help of sole pads.

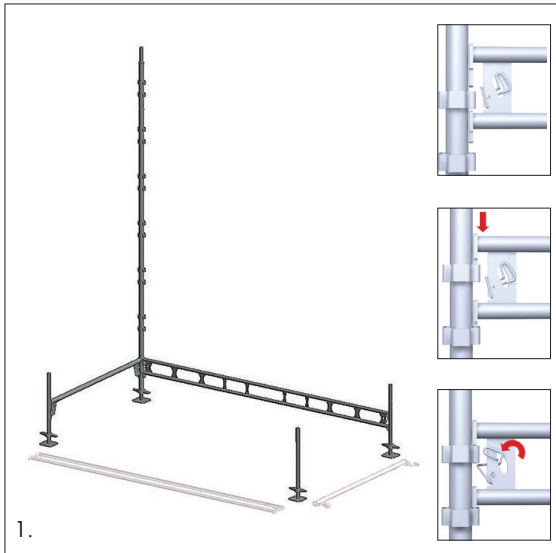

1. Erect the first standard and fit a transom and ledger beam to it.

The beams are fitted to the lowest group of pockets on the standard.

Lock the beams into position.

Fit standards and beams in order to complete the first lift.

If necessary, fit a plan brace in order to ensure that the stair tower is square.

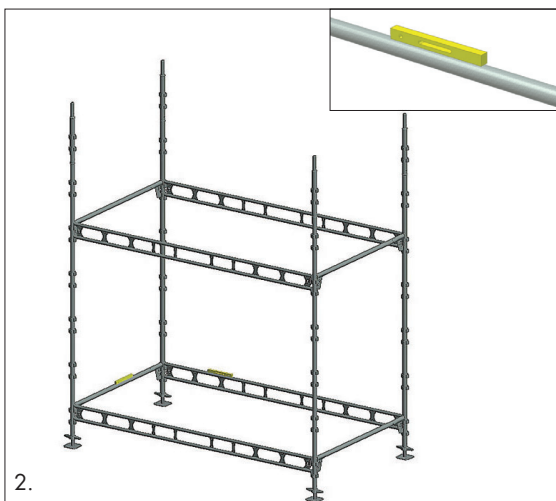

2. Fit the transom and ledger beams for the second lift depending on the type of stair flight to be used.

Then check the levels in both the transverse and longitudinal directions using a spirit level and adjust using the base jacks.

Fit the vertical diagonal braces and correct the vertical alignment of the standards.

Alternatively, brace the stair tower vertically using guardrail frames.

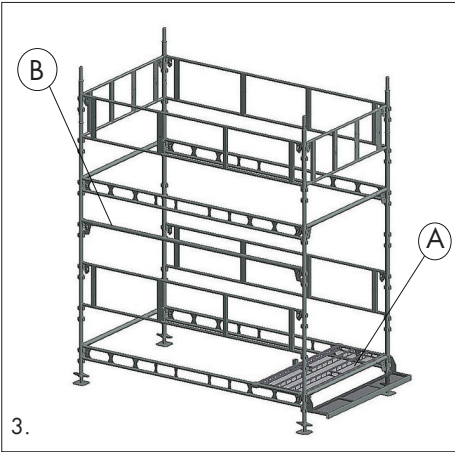

3. Install the first landing A so that the hooks rest on the ledger beams. Hook on an entrance step for easy access to the lowest lift.

Install 3050 guardrail frames at the lowest level.

Guardrail B should always be fitted every half metre next to 2.0 m stair flights. A 3050 single ledger can replace a 3050 guardrail SKR.

Install the second lift with guardrail frames in both the transverse and longitudinal direction.

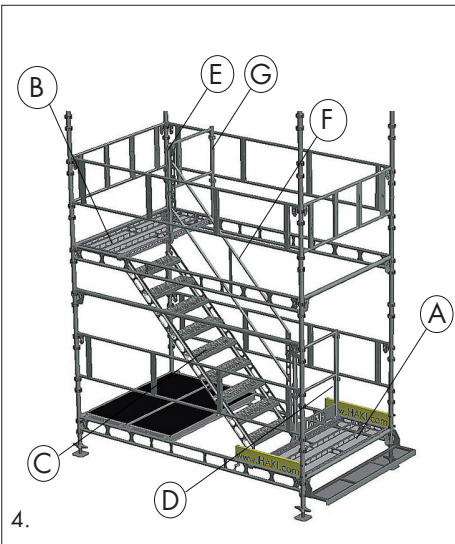

4. Stand on an erection platform or Steel Decks and install the second landing B.

Hook a stair flight C into the pockets of the landings.

Install a safety gate D on the lowest landing and a handrail post with wedge E.

Fit a handrail F and lock it. From behind the handrail, install a top guard frame G.

Fit toeboards at the lowest level if necessary.

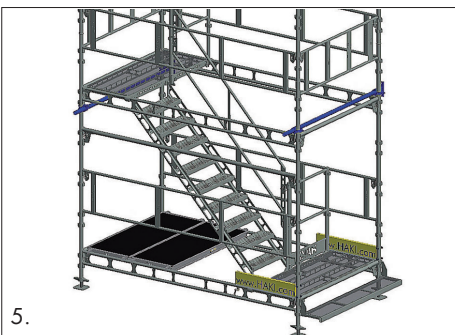

5. Tie the stair tower to structure using tube with load bearing couplers through both standards.

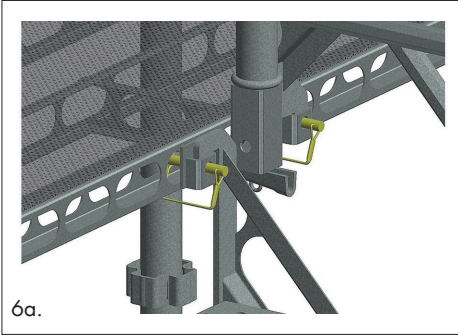

6a. The stair flight should be locked in the landing using locking pins (2 per flight).

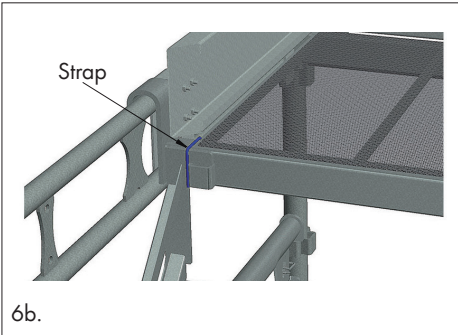

6b. For traditional stair tower, in the event of anticipated excessive wind conditions, it is recommended that the flights are secured (at the outboard top edge) by the use of a suitable, disposable strap.

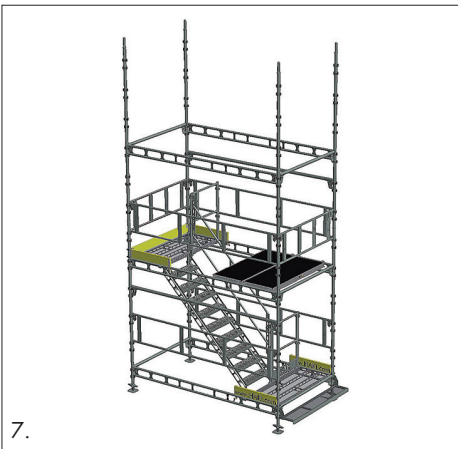

7. Lift up the erection platforms to the next level and install the next set of standards, transoms and ledger beams for the third lift. Install toeboards.

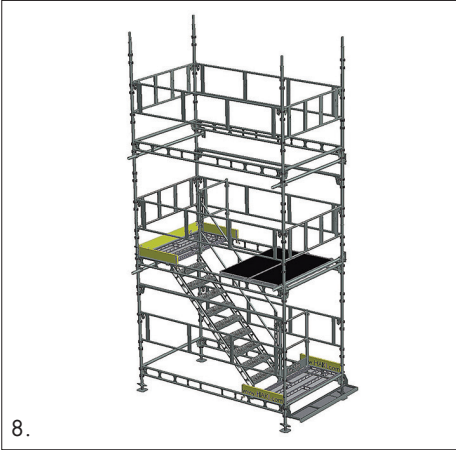

8. Install guardrail frames to next lift using AGR tools.

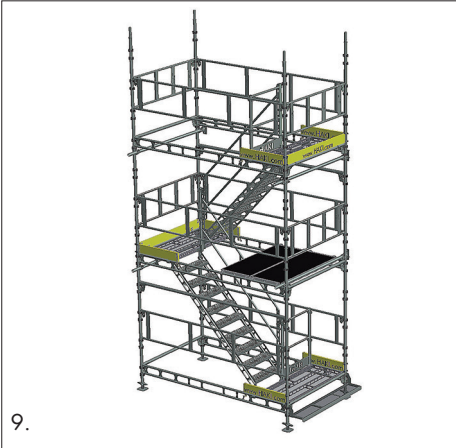

9. From the erection platforms, install the next landing. Remove the top guard frame. Install a stair flight, handrail post and handrail. Install all the toeboards, top guard frame and ties.

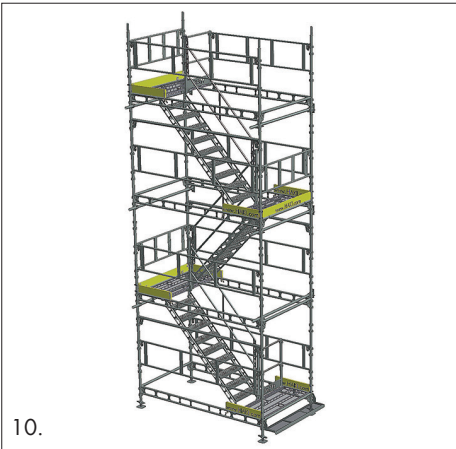

10. Continue erection up to the desired height as set out above.

On the top lift, guardrail frames are installed in both the transverse and longitudinal directions as well as toeboards and a safety gate.

Top landing with side exit, install a 2357 or 2210 guardrail frame on a guardrail post. Guardrail post is installed on the ledger beam. For intermediate side exits see step 10.1

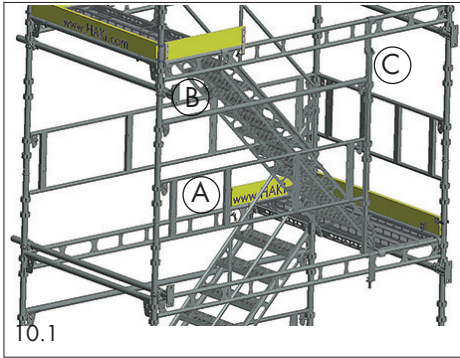

10.1. Intermediate side exits, install a 2210 guardrail frame A with respective 2210 guardrail B, on an intermediate standard C. Intermediate standard can be replaced with a guardrail post + guardpost extension.

For components not mentioned in this manual, see HAKI Component List or contact HAKI's technical department.

Information on safety when dismantling

1. Do not throw or drop materials to the ground. This may damage the material or cause personal injury. The materials must be lowered down to the ground by means of ropes or slings or passed down by hand.
2. If intermediate ties or tie rod tubes have been installed, they must not be removed until the dismantling process reaches the level in question.
3. Always observe and comply with the regulations published by the local authorities concerned.
4. Dismantlers should always be clipped to a single ledger or ledger beam during dismantling.
5. Reference should also be made to the section "Information on safety when erecting and dismantling" on page 9 in this manual.

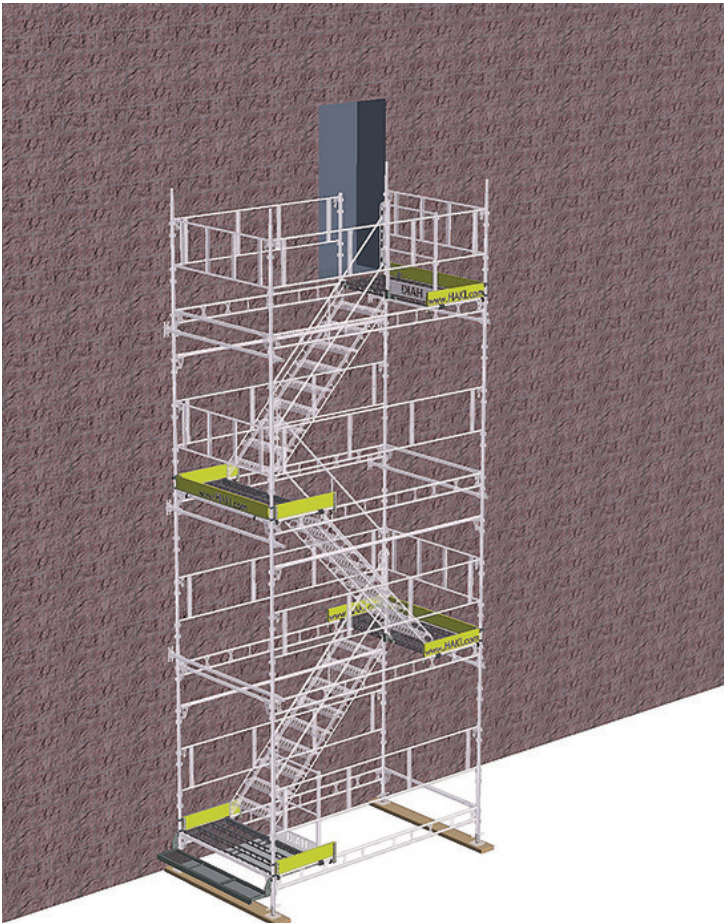

6.5m Symmetrical Stair Tower



1. Remove all the toeboards.

From behind the handrail, remove the top guard frame, the clip on post and the 2210mm guardrail frame.

Install two erection platforms or steel decks below the top landing and a temporary 1655mm ledger beam using AGR tools.



2. From the erection platforms, remove the handrail and handrail post.

Remove the stair flight.

Re-install the top guard frame.

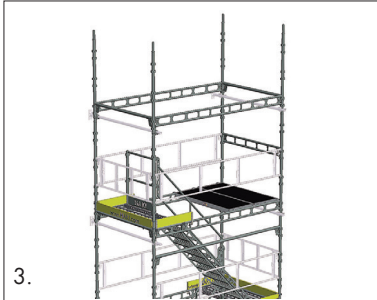

3. From the erection platforms remove the top landing.

Remove all the guardrail frames using AGR tools.

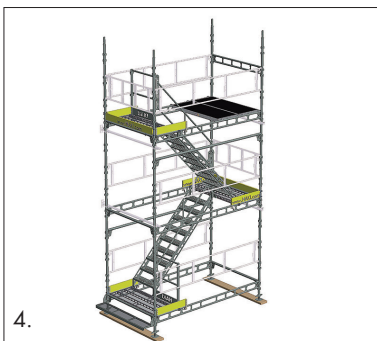

4. Remove lift and ties.

Repeat same dismantling procedure until dismantling is complete.

For other dismantling procedures, please contact HAKI's technical department.

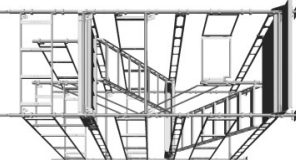
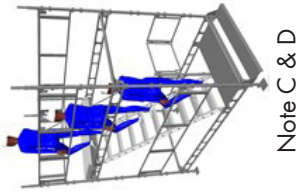
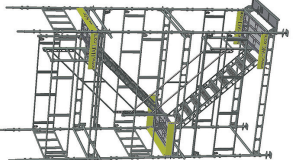
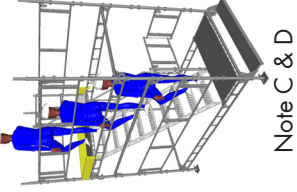
STAIR TOWER (Load Class)	APPLICATIONS			FIRE ESCAPES & PUBLIC EVENTS	PERMISSIBLE PEOPLE PER LIFT 1kN ~ 100kg ~ 1 person
	LIGHT DUTY NOTE: G	MEDIUM DUTY	HEAVY DUTY		
 TRADITIONAL STAIR TOWER (MK1) SWL 4kN/m ²	✓ YES	✓ YES	✓ YES	✗ NO	 Note C & D 7 Note C
 SYMMETRICAL STAIR TOWER (MK2) SWL 4kN/m ²	✓ YES	✓ YES	✓ YES	✗ NO	 Note C & D 7 Note C
NOTES A. Use this table as guidance only. Each application needs to be considered on its own merits. C. 4 people per landing + 3 people per flight.	(Applies to 1m, 1.5m and 2m flights) D. People on landings omitted for clarity. Refer to the red number for permissible people.			G. Occasional use. Inspection. Light maintenance work, etc.	

Permissible loads

The permissible load on stair flights and landings is 4.0 kN/m² evenly distributed.

The maximum permissible leg load is 36.2 kN.

For higher loads, please contact HAKI's technical department.

Stair Tower height [m]	Number of persons permitted	
	On Jacks 2 m Tie Pattern	Suspended
8	32	32
10	39	39
12	46	46
14	53	53
16	60	58
18	67	56
20	74	53
22	81	51
24	88	48
26	95	46
28	102	43
30	109	41
32	110	38
34	108	36
36	106	33
38	104	30
40	102	28
42	100	25
44	98	23
46	96	20
48	94	18
50	92	15

NOTES:

- On jacks: Permissible people change if a 4 m tie pattern is used.
- Suspended: Restricted by the SWL of the pins (SWL: 20kN). Must be fully braced.

Base jacks

The stair tower is erected on base jacks of type BS, which are adjustable between 55 and 570 mm.

If greater adjustment is needed, lower the base jacks and connect the beams to the next group of pockets.

This means that it is always possible to adjust the standards so as to make the beams level.

Standards

Standards of length 3000 or 2000 mm are normally used in the stair tower.

However, 1500 mm standards may be used at the bottom of the scaffold in accordance with the alternative method of erection described on page 25.

Beams

The stair tower is erected using ledger beams or single ledger as ledger and transom beams with 2000 mm, 1500 or 1000 mm between the lifts, depending on the stair flight to be used.

Each lift must be provided with beams on both the inside and outside. The bottom lift must always be placed at the lowest possible level.

Guardrails

Stair flights must be provided with handrails on the inside and the stair tower must be provided with guardrails at every half metre on the outside of the stair flight.

The landing must be provided with guardrail frames or double guardrails and toeboards.

Bracing and tying in

The stair tower must be anchored to the façade or equivalent at every lift level from both the inside and outside standard.

If the stair tower is built into the scaffolding, this requirement applies to the anchorages for the scaffolding.

Normally, the stair tower is erected with the direction of passage of the stairways parallel with the scaffolding or façade. Where stairways are installed at right angles to the façade, both the standards of the outer pair of standards must be diagonally braced against the scaffolding at every 4th metre in height.

Wind load

When calculating the wind load on the stair tower, the following wind area values may be used for unsheeted towers.

Total Effective frontal Area [m²]		
Stair Tower	3.05 Side	1.655 Side
	<u>Effective</u> frontal Area m ² /m-Height	<u>Effective</u> frontal Area m ² /m-Height
2.0m Lift	1.19	1.58
Top Lift (ONLY)	0.73	0.83

HAKI Tripod

In order to increase the permissible construction height for a HAKI stair tower, HAKI Tripod units can be used at the bottom of the structure.

Start by using HAKI Tripod units as vertical members and continue with FSSH standards when the load on the standards becomes lower higher up in the structure.

Using BS 60 base jacks and the adapter tripod 60, the permissible load per tripod is up to 200 kN. Contact HAKI's technical department for information.



HAKI Tripod for high loads on standards in high stair towers.



HAKI Stair Tower Symmetrical and Traditional – clockwise ascent

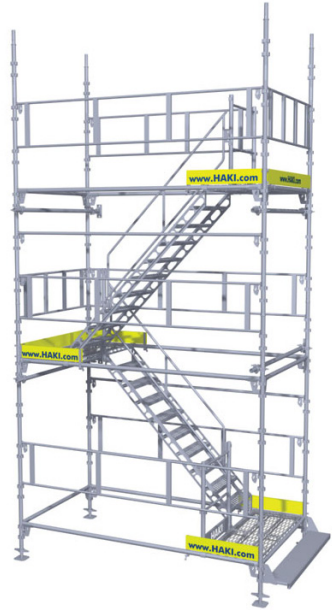

HAKI Stair Tower Symmetrical – anticlockwise ascent



HAKI Stair Tower Symmetrical – parallel, double stair flights

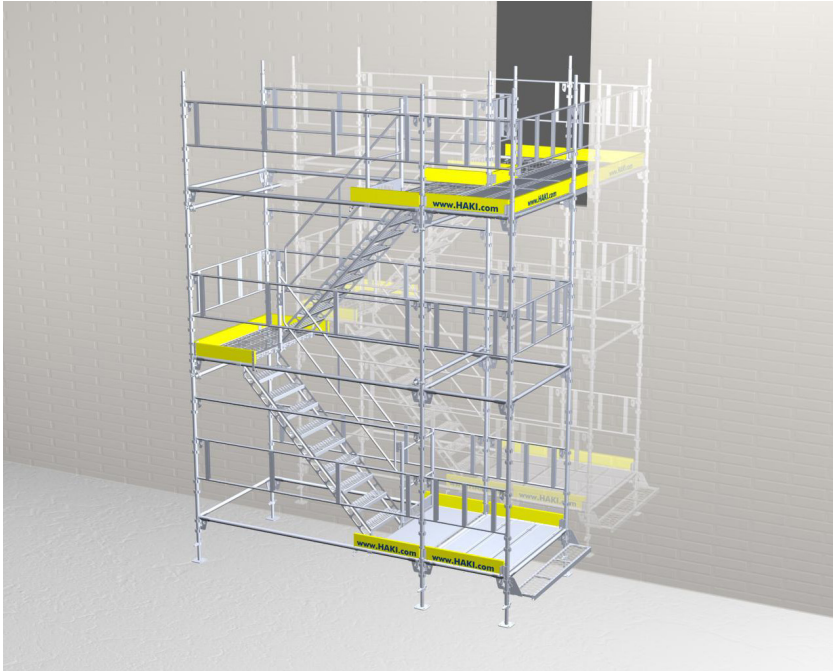

HAKI Stair Tower Symmetrical and Traditional – 1.5 m stair flight at the bottom

Symmetrical stair tower

HAKI Stair Tower connected to a stair tower on the inside of the building

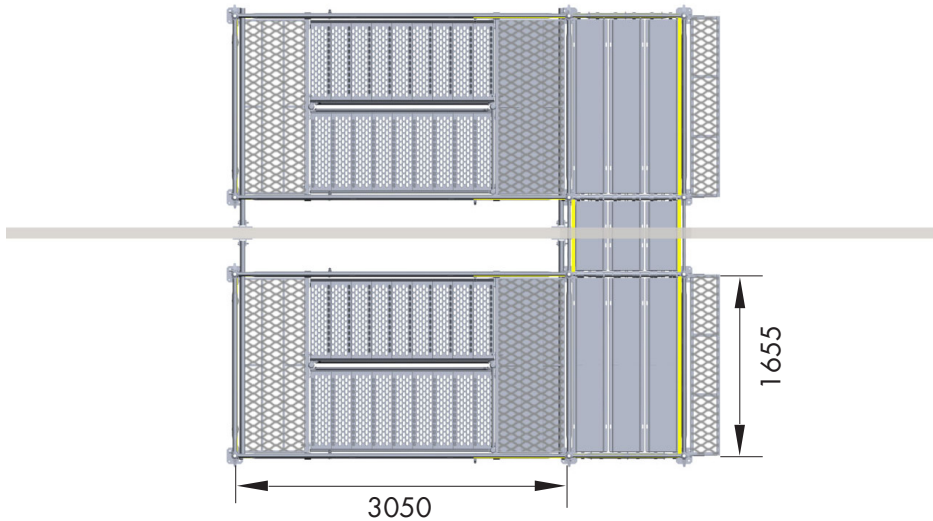

Symmetrical stair tower

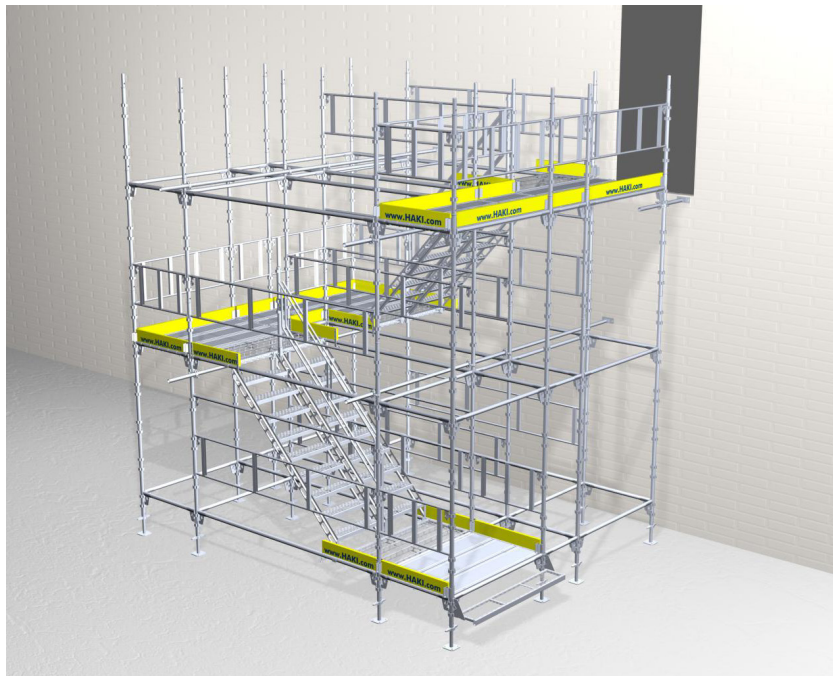

HAKI Stair Tower with double stair flights and extended landings

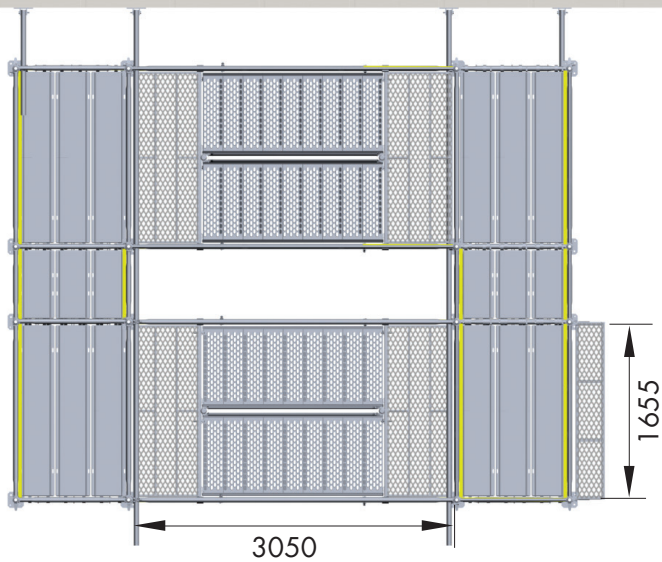

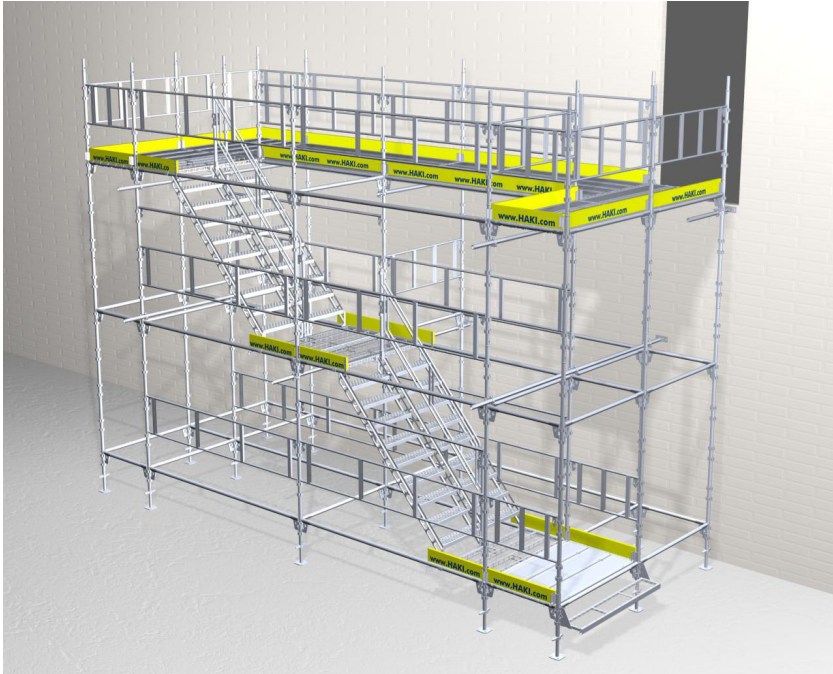
Symmetrical stair tower

HAKI Stair Tower with double stair flights over two bays, extended landings and access via scaffold

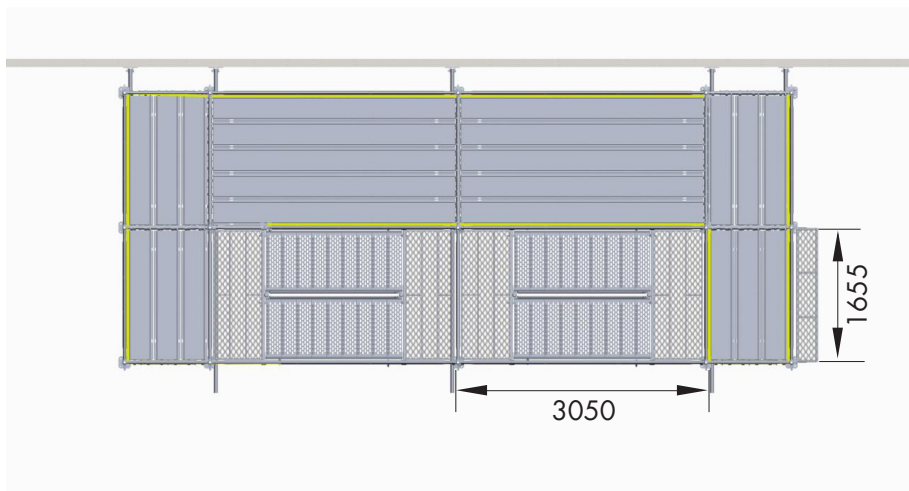

Methods of erection when guardrail frame is fitted in advance



In order to be able to fit guardrails prior to decking, using HAKI's advance guardrail tool or with the aid of other guardrail fitting devices, the external standards must be one metre higher than the next lift.

Some alternative methods of erection to achieve this are shown here.

These methods of erection also facilitate the use of temporary guardrails.

For permissible loads on standards, see page 18.
In other respects, see instructions for the fitting devices in question.

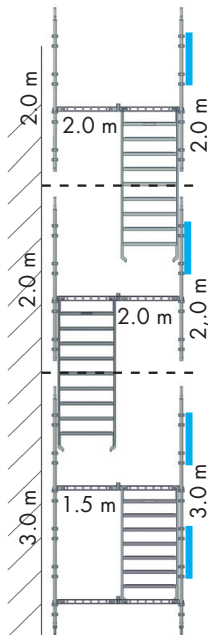

With a first lift height of 1.5 m, start with 3.0 m standards. Continue with lift heights of 2.0 m, using 2.0 m standards.

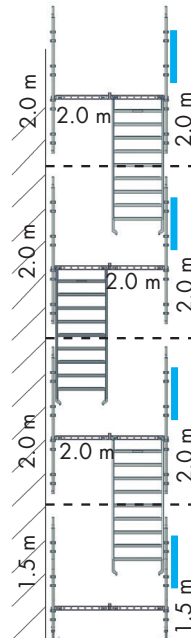

With lift heights of 2.0 m, start with 1.5 m standards. Continue with 2.0 m standards.

HAKI P-Frame Technical Update Information - 01/07/2019

HAKI MK1 – P-Frame before 2007. Addition of Adapter 35 and Double Coupler

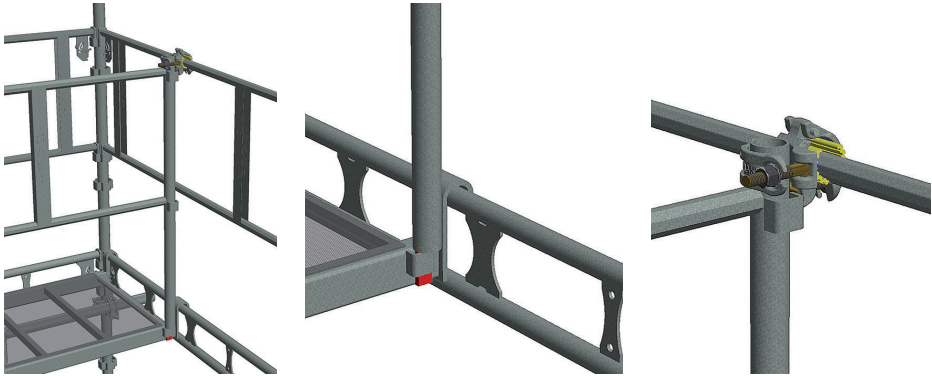

HAKI MK1 – P-Frame before 2007. Addition of Adapter 35 and Double Coupler

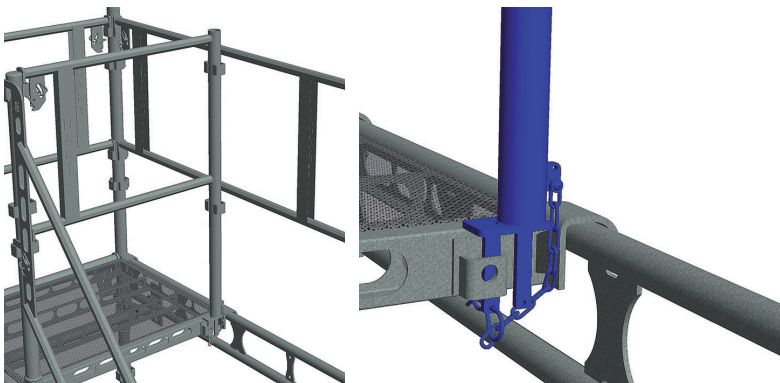

HAKI MK3 – P-Frame after 2018. Pin and chain connection (No additional coupler needed)

SAFETY CHECKLIST

1. Supporting surface checked with regard to load-bearing capacity
2. Distance to wall or similar as short as possible
3. Scaffold aligned correctly horizontally and vertically
4. Components correctly fitted and locked
5. Bracing correctly fitted
6. Anchoring with right number and placing of ties
7. Decking correctly fitted
8. Guardrail with toeboard if drop is two metres or more
9. Suitable means of access to scaffold
10. Scaffold erected for correct class of load



Experience

With over 60 years experience to call on, HAKI has gained a leading reputation in its field. With its own R & D and manufacturing facilities, the company now operates throughout Europe and its equipment is in use worldwide. With all products designed and manufactured to ISO 9001:2008, and a comprehensive training and support infrastructure, you can rely on HAKI for support.



Training

The Company's dedicated Training Centre is equipped with the full range of HAKI products where a comprehensive choice of courses is offered. With the benefit of this training, all users of HAKI products can be assured that the equipment is being employed safely and effectively.



Support

From computerised estimating facilities to on site assessment and project back up, HAKI is with its customers every step of the way. Working with HAKI means far more than just proven equipment, it means working with people who understand the scaffolding industry. Whatever the project, the company is committed to ensuring every user enjoys the full benefits associated with the use of HAKI - maximising the savings, profitability, and above all, SAFETY.

Health and Safety at Work Act, 1974

HAKI equipment is designed to meet the requirements of the above Act, Section 6.

It is also the customer's responsibility to comply with the requirements of this Act, particularly to use the equipment in accordance with current codes of practice and in ensuring that components are in good working condition prior to each use.

We are able to provide assistance and advice on matters relating to safe and proper use of HAKI equipment.

